

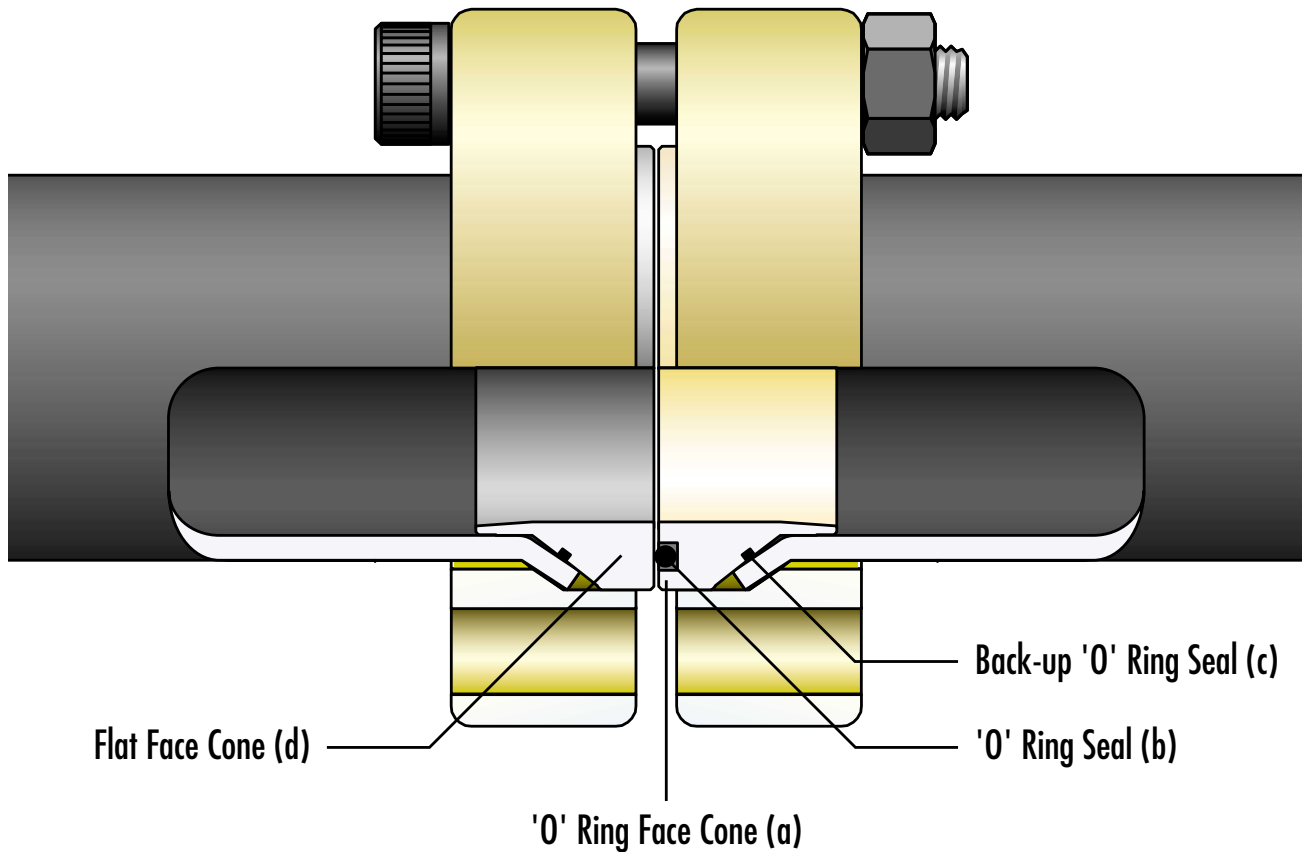

Flared System



The flared configuration is based on flaring the pipe ends to 37° and utilizing flanges and internal cones. 'O'ring face cone (a) with 'o'ring seal (b) mating to flat face cone (d). Both internal cones have back-up 'o'rings (c).

PREPARATION:

The flange is slipped onto the pipe before flaring. After flaring, the cone is located into the pipe. Bolting the flanges together draws the flared pipes and cones in contact with each other providing a leakfree connection.

Standard flare flanges and pipe are available from 1/2" - 3" and pressures to 6000 PSI.

The standard connection styles offered conform to SAE and ISO 4-bolt flanges. Other flange patterns may also be available.



TMI® 37° Flaring and Connection Procedure

The Flare Flange connection consists of pipe suitable for cold forming (reference pages B6-B7), flare flanges, flare cones with elastomer seals and bolting hardware.



Step 1: Cut pipe end square, deburr and clean. Slip flange onto the pipe before flaring. Place pipe into the flaring machine with the correct dies and flaring cone to suit the pipe size.



Step 2: Pipe is to protrude to the stop on the die. Lubricate the flaring cone, start the machine, flare the pipe end until fully formed against the die. Stop the machine, remove the pipe from the die.



Step 3: Clean and visually inspect the flare. The surface of the flare should be smooth and free of any defects.



Step 4: Select the correct pipe cone style (ref. pgs. B4-B5). Insert pipe cone into the flared end of the pipe (use rubber hammer if required).





Step 5: Select the required bolting hardware from section Section R of this catalogue.



Step 6: Tighten bolts to the torque values specified. Always tighten bolts in a cross-over sequence and ensure that the flanges are parallel.

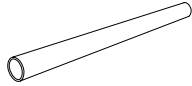
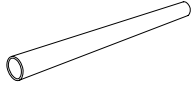
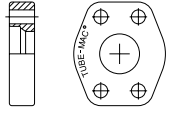
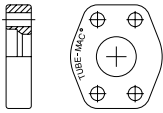
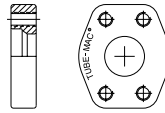
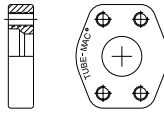
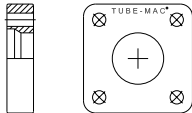
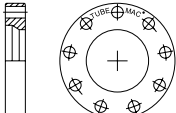

Flared System - Visual Index

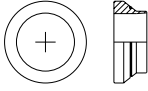
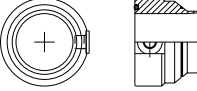
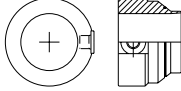
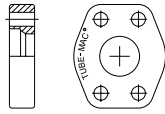
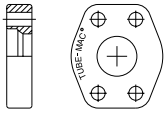
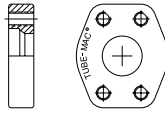
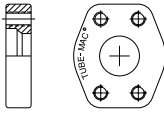
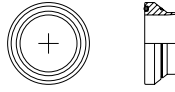
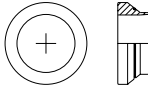
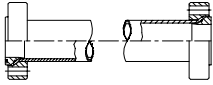
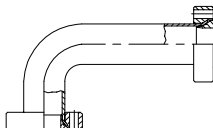
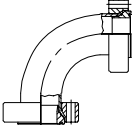
<p>PIPES</p>	<p>CARBON STEEL PIPE</p>  <p>1/2" - 3" Page B6</p>	<p>STAINLESS STEEL PIPE</p>  <p>1/2" - 3" Page B7</p>	<p>FLARE FLANGES</p>	<p>FFC34 SAE CODE 61 WITH CLEARANCE HOLES</p>  <p>1/2" - 3" Page B8</p>
<p>FFC64 SAE CODE 62 WITH CLEARANCE HOLES</p>  <p>1/2" - 2" Page B8</p>	<p>FFT34 SAE CODE 61 WITH UNC TAPPED HOLES</p>  <p>1/2" - 3" Page B9</p>	<p>FFT64 SAE CODE 62 WITH UNC TAPPED HOLES</p>  <p>1/2" - 2" Page B9</p>	<p>FFC74 ISO 6164 WITH CLEARANCE HOLES</p>  <p>2 1/2" - 3" Page B10</p>	<p>FFC49 TMI® 9-BOLT WITH CLEARANCE HOLES</p>  <p>2 1/2" - 3" Page B11</p>
<p>FLARE FLANGE CONES</p>	<p>CO CONE-'O' RING FACE</p>  <p>1/2" - 3" Page B12</p>	<p>CF CONE-FLAT FACE</p>  <p>1/2" - 3" Page B13</p>	<p>COP CONE-'O' RING FACE WITH PILOT PORT</p>  <p>1/2" - 3" Page B14</p>	<p>CFP CONE-FLAT FACE WITH PILOT PORT</p>  <p>1/2" - 3" Page B15</p>
<p>FLARE FLANGES Reducing</p>	<p>FFCR34 SAE CODE 61 WITH CLEARANCE HOLES</p>  <p>1/2" - 3" Page B16</p>	<p>FFCR64 SAE CODE 62 WITH CLEARANCE HOLES</p>  <p>1/2" - 2" Page B16</p>	<p>FFTR34 SAE CODE 61 WITH UNC TAPPED HOLES</p>  <p>1/2" - 3" Page B18</p>	<p>FFTR64 SAE CODE 62 WITH UNC TAPPED HOLES</p>  <p>1/2" - 2" Page B18</p>
<p>FLARE FLANGE CONES Reducing</p>	<p>COR CONE-'O' RING FACE REDUCING</p>  <p>1/2" - 3" Page B17</p>	<p>CFR CONE-FLAT FACE REDUCING</p>  <p>1/2" - 3" Page B19</p>		
<p>PIPE ASSEMBLY</p>	<p>PAF FLARE FLANGE PIPE ASSEMBLY</p>  <p>1/2" - 3" Page B20-21</p>	<p>BPAF FLARE FLANGE BENT PIPE ASSEMBLY</p>  <p>1/2" - 3" Page B22-23</p>		
<p>FLARE FLANGE ELBOW ASSEMBLY</p>	<p>A/FFE FLARE FLANGE ELBOW ASSEMBLY</p>  <p>1/2" - 3" Page B24-25</p>			



Flare Flange Connections - Schedule 40/80

Typical Flare Union Connection

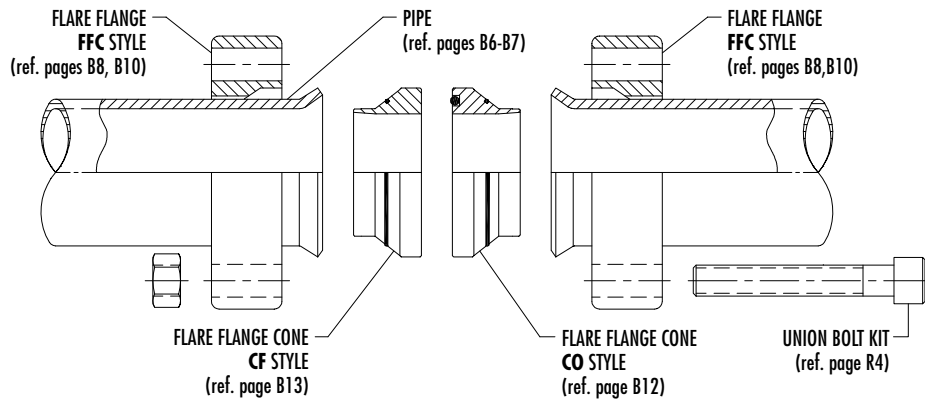

Typical Flare ('O' Ring Face) to Flat Face Component Connection

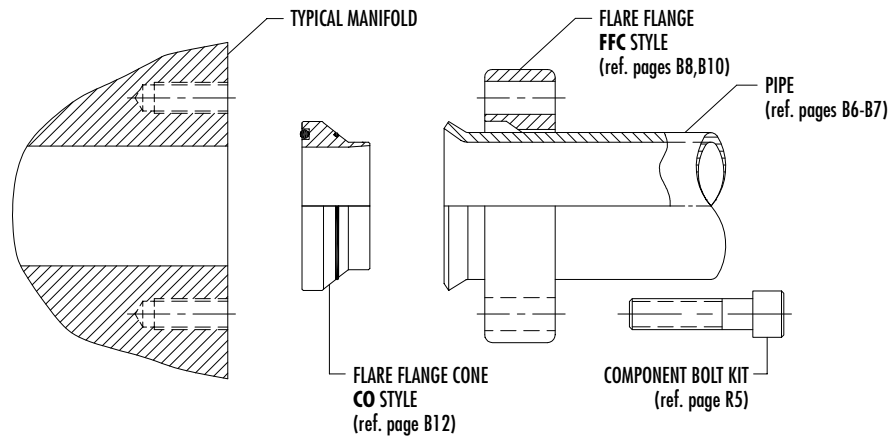

Typical Flare (Flat Face) to Split Flange Connection

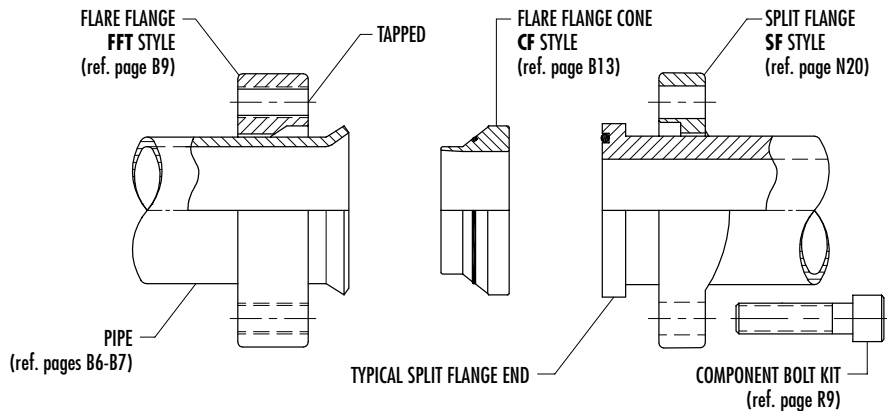



Flare Flange Connections - Schedule 40/80

Typical Flare (Flat Face) to 'O' Ring Face Component Connection

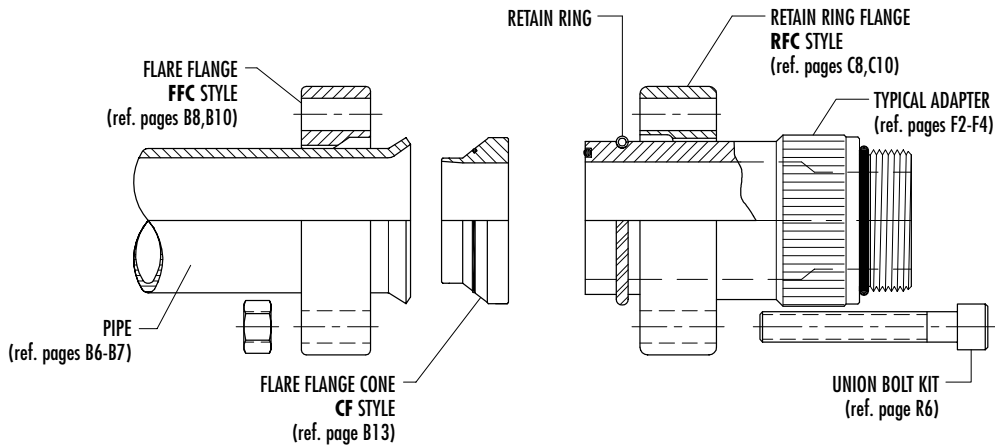

Typical Flare ('O' Ring Face) to Retain Ring Pipe Connection

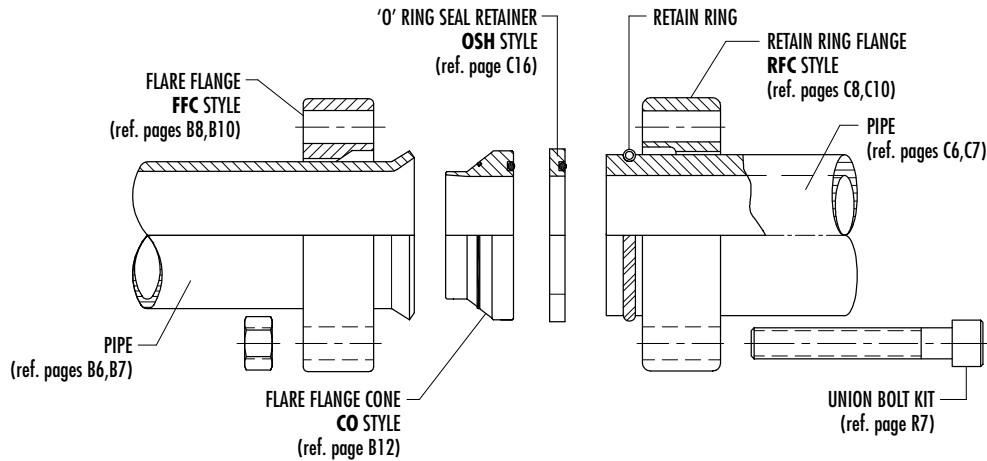

Typical Flare (Flat Face) to Retain Ring Pipe Connection

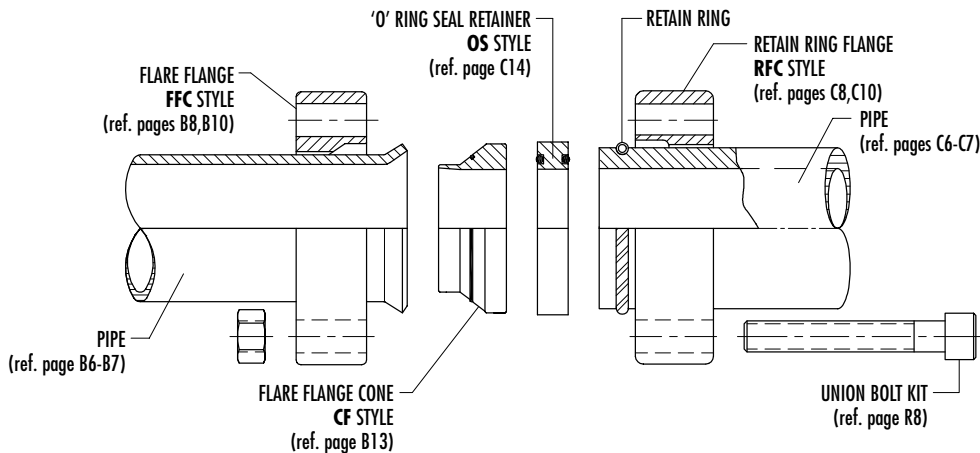

TMI® Carbon Steel Pipe

Suitable for Flaring

Schedule 40/80/160 Pipe

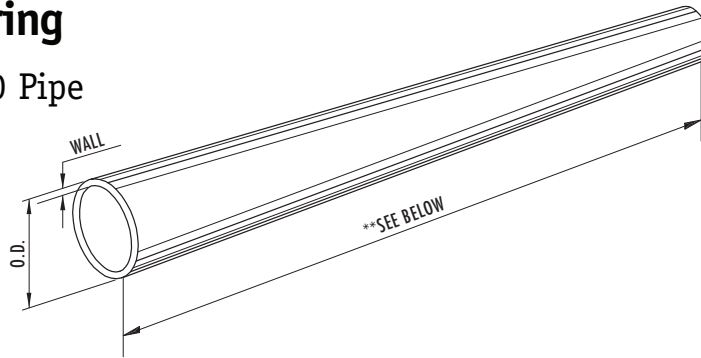

TMP52CD

A519-DIN 2391c St 52.4 NBK Phosphated High Quality Bendable Cold Drawn Seamless Carbon Steel

Schedule 40

Nominal Size	Pipe Part No.	OD x Wall (in)	Bore Dia. (in)	WT. lbs/ft	Working Pressure PSI (bar)
1/2"	TMP52CD-SCH40-050x**	0.840 x 0.109	0.622	0.85	6000 (420)
3/4"	TMP52CD-SCH40-075x**	1.050 x 0.113	0.824	1.13	5000 (345)
1"	TMP52CD-SCH40-100x**	1.315 x 0.133	1.049	1.68	4700 (325)
1 1/4"	TMP52CD-SCH40-125x**	1.660 x 0.140	1.380	2.27	3900 (270)
1 1/2"	TMP52CD-SCH40-150x**	1.900 x 0.145	1.610	2.72	3500 (240)
2"	TMP52CD-SCH40-200x**	2.375 x 0.154	2.067	3.65	2900 (200)

**INDICATE LENGTH (inches), AVAILABLE IN 240" OR 360" LENGTHS

Schedule 80

Nominal Size	Pipe Part No.	OD x Wall (in)	Bore Dia. (in)	WT. lbs/ft	Working Pressure PSI (bar)
1/2"	TMP52CD-SCH80-050x**	0.840 x 0.147	0.546	1.09	6000 (420)
3/4"	TMP52CD-SCH80-075x**	1.050 x 0.154	0.742	1.47	6000 (420)
1"	TMP52CD-SCH80-100x**	1.315 x 0.179	0.957	2.17	6000 (420)
1 1/4"	TMP52CD-SCH80-125x**	1.660 x 0.191	1.278	2.99	5400 (370)
1 1/2"	TMP52CD-SCH80-150x**	1.900 x 0.200	1.500	3.63	4900 (340)
2"	TMP52CD-SCH80-200x**	2.375 x 0.218	1.939	5.02	4200 (290)
2 1/2"	TMP52CD-SCH80-250x**	2.875 x 0.276	2.323	7.65	4500 (310)
3"	TMP52CD-SCH80-300x**	3.500 x 0.300	2.900	10.24	3900 (270)
4"	TMP52CD-SCH80-400x**	4.500 x 0.337	3.826	14.98	3420 (235)

**INDICATE LENGTH (inches), AVAILABLE IN 240" OR 360" LENGTHS

Schedule 160

Nominal Size	Pipe Part No.	OD x Wall (in)	Bore Dia. (in)	WT. lbs/ft	Working Pressure PSI (bar)
1 1/2"	TMP52CD-SCH160-150x**	1.900 x 0.281	1.338	4.86	6930 (478)
2"	TMP52CD-SCH160-200x**	2.375 x 0.343	1.689	7.44	6750 (465)
2 1/2"	TMP52CD-SCH160-250x**	2.875 x 0.375	2.125	10.01	6030 (415)

**INDICATE LENGTH (inches), AVAILABLE IN 240" OR 360" LENGTHS

TMP44HR

A519 - Cleaned & Phosphated Seamless Carbon Steel

Schedule 40

Nominal Size	Pipe Part No.	OD x Wall (in)	Bore Dia. (in)	WT. lbs/ft	Working Pressure PSI (bar)
2 1/2"	TMP44HR-SCH40-250x**	2.875 x 0.203	2.469	5.79	2600 (180)
3"	TMP44HR-SCH40-300x**	3.500 x 0.216	3.068	7.57	2300 (160)

**INDICATE LENGTH (inches), AVAILABLE IN 360" LENGTHS

- MAXIMUM ALLOWABLE WORKING PRESSURES ARE BASED ON THE LOWER OF THE PIPE RATING PER ANSI B31.3 OR THE CONNECTION RATING



TMI[®] Stainless Steel Pipe

Suitable for Flaring

Schedule 40/80 Pipe

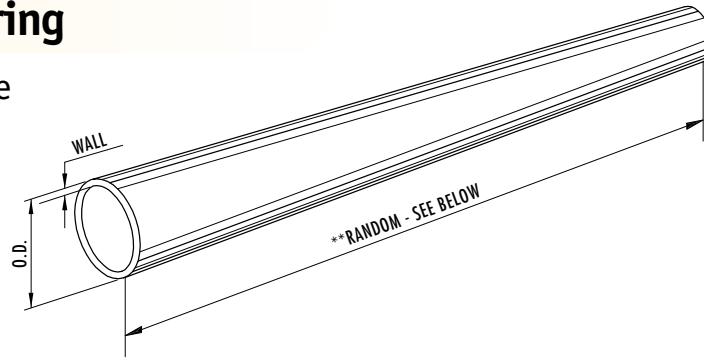

TMP304SS/316SS

A312-Seamless Stainless Steel (supplied as dual certification ie. 304/304L or 316/316L)

Schedule 40

Nominal Size	304/304L Stainless Steel Pipe Part No.	316/316L Stainless Steel Pipe Part No.	OD x Wall (in)	Bore Dia. (in)	WT. lbs/ft	Working Pressure PSI (bar)
1/2"	TMP304SS-SCH40-050x**	TMP316SS-SCH40-050x**	0.840 x 0.109	0.622	0.85	5000 (345)
3/4"	TMP304SS-SCH40-075x**	TMP316SS-SCH40-075x**	1.050 x 0.113	0.824	1.13	4000 (275)
1"	TMP304SS-SCH40-100x**	TMP316SS-SCH40-100x**	1.315 x 0.133	1.049	1.68	3800 (260)
1 1/4"	TMP304SS-SCH40-125x**	TMP316SS-SCH40-125x**	1.660 x 0.140	1.380	2.27	3100 (215)
1 1/2"	TMP304SS-SCH40-150x**	TMP316SS-SCH40-150x**	1.900 x 0.145	1.610	2.72	2800 (190)
2"	TMP304SS-SCH40-200x**	TMP316SS-SCH40-200x**	2.375 x 0.154	2.067	3.65	2400 (165)
2 1/2"	TMP304SS-SCH40-250x**	TMP316SS-SCH40-250x**	2.875 x 0.203	2.469	5.79	2500 (175)
3"	TMP304SS-SCH40-300x**	TMP316SS-SCH40-300x**	3.500 x 0.216	3.068	7.58	2000 (140)

Schedule 80

Nominal Size	304/304L Stainless Steel Pipe Part No.	316/316L Stainless Steel Pipe Part No.	OD x Wall (in)	Bore Dia. (in)	WT. lbs/ft	Working Pressure PSI (bar)
1/2"	TMP304SS-SCH80-050x**	TMP316SS-SCH80-050x**	0.840 x 0.147	0.546	1.09	6000 (420)
3/4"	TMP304SS-SCH80-075x**	TMP316SS-SCH80-075x**	1.050 x 0.154	0.742	1.47	5700 (390)
1"	TMP304SS-SCH80-100x**	TMP316SS-SCH80-100x**	1.315 x 0.179	0.957	2.17	5300 (365)
1 1/4"	TMP304SS-SCH80-125x**	TMP316SS-SCH80-125x**	1.660 x 0.191	1.278	2.99	4400 (300)
1 1/2"	TMP304SS-SCH80-150x**	TMP316SS-SCH80-150x**	1.900 x 0.200	1.500	3.63	4000 (275)
2"	TMP304SS-SCH80-200x**	TMP316SS-SCH80-200x**	2.375 x 0.218	1.939	5.02	3400 (235)
2 1/2"	TMP304SS-SCH80-250x**	TMP316SS-SCH80-250x**	2.875 x 0.276	2.323	7.65	3600 (250)
3"	TMP304SS-SCH80-300x**	TMP316SS-SCH80-300x**	3.500 x 0.300	2.900	10.24	3200 (220)

TMP2205SS

A790 - Seamless Duplex Stainless Steel

Schedule 80

Nominal Size	Pipe Part No.	OD x Wall (in)	Bore Dia. (in)	WT. lbs/ft	Working Pressure PSI (bar)
1 1/4"	TMP2205SS-SCH80-125x**	1.660 x 0.191	1.278	2.99	6000 (420)
1 1/2"	TMP2205SS-SCH80-150x**	1.900 x 0.200	1.500	3.63	6000 (420)
2"	TMP2205SS-SCH80-200x**	2.375 x 0.218	1.939	5.02	5200 (360)

**INDICATE LENGTH (inches), AVAILABLE IN RANDOM LENGTHS UP TO 240"

- TO ORDER A FLARE FLANGE PIPE ASSEMBLY REFERENCE PAGES B20-B23
- MAXIMUM ALLOWABLE WORKING PRESSURES ARE BASED ON THE LOWER OF THE PIPE RATING PER ANSI B31.3 OR THE CARBON STEEL CONNECTION RATING
- FOR PIPING SYSTEMS CONSISTING OF ALL STAINLESS STEEL COMPONENTS, PRESSURE RATINGS WILL BE LESS THAN THAT SHOWN ABOVE (CONTACT FACTORY)



Flare Flanges

SAE - Flanges with Clearance Holes

To be used with
flared pipe only
Ref. pages B6-B7

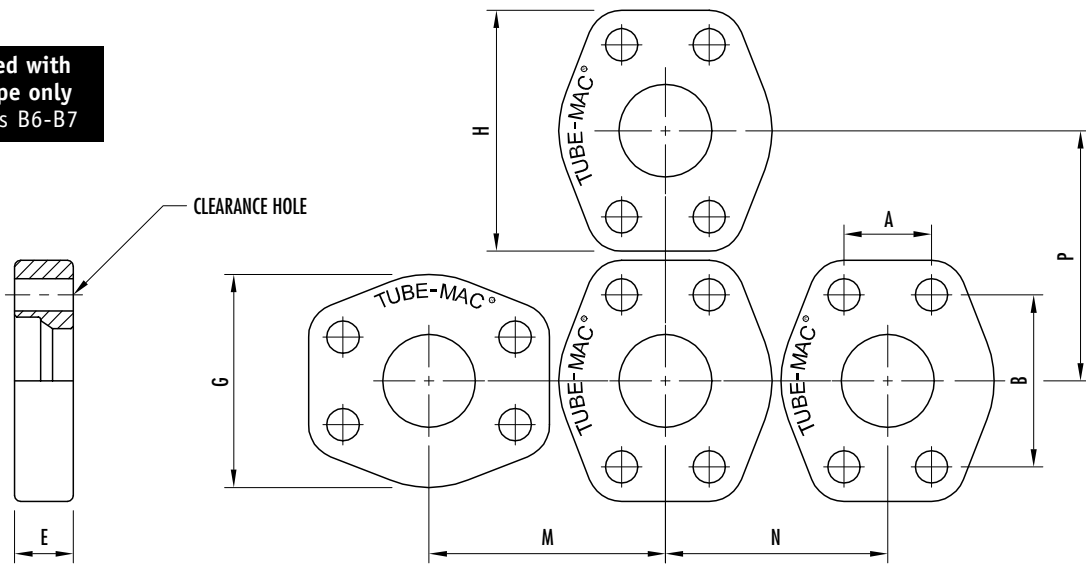

FFC34 Flare Flange - SAE Code 61 With Clearance Holes

Standard Pressure Series 2000-5000 PSI (140-350 bar)

Size	Flange Part No.	Dimensions (in)								Bolt Minimum Grade 5	WT. lbs/pc	Working Pressure PSI (bar)	Bolt Torque ft.lbs.
		A	B	G	H	M	N	P	E				
1/2"	FFC34-050	0.69	1.50	1.81	2.16	2.05	1.93	2.32	0.81	5/16" UNC	0.56	5000 (350)	15-18
3/4"	FFC34-075	0.88	1.88	2.06	2.56	2.40	2.17	2.68	0.82	3/8" UNC	0.59	5000 (350)	20-30
1"	FFC34-100	1.03	2.06	2.31	2.76	2.64	2.44	2.87	0.87	3/8" UNC	0.64	5000 (350)	20-30
1 1/4"	FFC34-125	1.19	2.31	2.88	3.11	3.11	2.99	3.23	0.91	7/16" UNC	0.85	4000 (275)	40-50
1 1/2"	FFC34-150	1.41	2.75	3.25	3.66	3.58	3.35	3.78	1.06	1/2" UNC	1.49	3000 (210)	80-90
2"	FFC34-200	1.69	3.06	3.81	4.02	4.02	3.94	4.13	1.22	1/2" UNC	2.17	3000 (210)	80-90
2 1/2"	FFC34-250	2.00	3.50	4.28	4.49	4.49	4.37	4.61	1.40	1/2" UNC	3.08	2500 (175)	80-90
3"	FFC34-300	2.44	4.19	5.16	5.28	5.35	5.24	5.39	1.67	5/8" UNC	4.60	2000 (140)	110-120

FFC64 Flare Flange - SAE Code 62 With Clearance Holes

High Pressure Series 6000 PSI (420 bar)

Size	Flange Part No.	Dimensions (in)								Bolt Minimum Grade 5	WT. lbs/pc	Working Pressure PSI (bar)	Bolt Torque ft.lbs.
		A	B	G	H	M	N	P	E				
1/2"	FFC64-050	0.72	1.59	1.88	2.22	2.20	2.09	2.32	0.81	5/16" UNC	0.56	6000 (420)	15-18
3/4"	FFC64-075	0.94	2.00	2.38	2.81	2.76	2.68	2.95	1.02	3/8" UNC	0.97	6000 (420)	20-30
1"	FFC64-100	1.09	2.25	2.75	3.19	3.19	2.99	3.35	1.03	7/16" UNC	1.27	6000 (420)	40-50
1 1/4"	FFC64-125	1.25	2.63	3.06	3.75	3.58	3.27	3.90	1.25	1/2" UNC	1.89	6000 (420)	80-90
1 1/2"	FFC64-150	1.44	3.13	3.75	4.44	4.25	3.98	4.57	1.38	5/8" UNC	3.32	6000 (420)	110-120
2"	FFC64-200	1.75	3.81	4.50	5.25	5.04	4.72	5.39	1.68	3/4" UNC	5.00	6000 (420)	120-130

• FOR BOLT KITS - REFERENCE SECTION R

MATERIAL: FORGED CARBON STEEL, YELLOW ZINC DICHROMATE PLATED, (STAINLESS STEEL AVAILABLE)



Flare Flanges

SAE - Flanges with Tapped Holes

To be used with flared pipe only
Ref. pages B6-B7

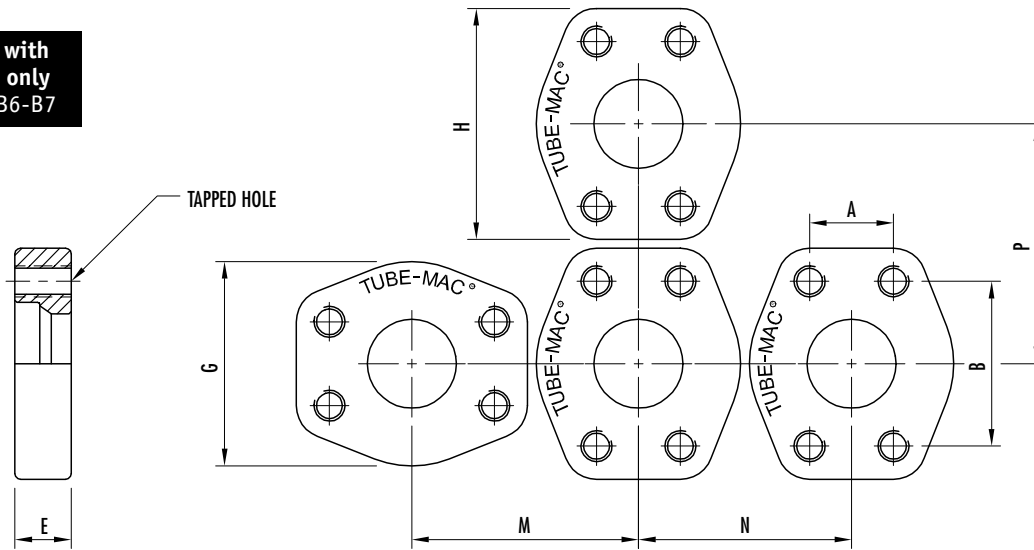

FFT34 Flare Flange - SAE Code 61 With Tapped Holes

Standard Pressure Series 2000-5000 PSI (140-350 bar)

Size	Flange Part No.	Dimensions (in)								Tap UNC-2B	WT. lbs/pc	Working Pressure PSI (bar)	Bolt Torque ft.lbs.
		A	B	G	H	M	N	P	E				
1/2"	FFT34-050	0.69	1.50	1.81	2.16	2.05	1.93	2.32	0.81	5/16"-18	0.56	5000 (350)	15-18
3/4"	FFT34-075	0.88	1.88	2.06	2.56	2.40	2.17	2.68	0.82	3/8"-16	0.63	5000 (350)	20-30
1"	FFT34-100	1.03	2.06	2.31	2.76	2.64	2.44	2.87	0.87	3/8"-16	0.68	5000 (350)	20-30
1 1/4"	FFT34-125	1.19	2.31	2.88	3.11	3.11	2.99	3.23	0.91	7/16"-14	0.90	4000 (275)	40-50
1 1/2"	FFT34-150	1.41	2.75	3.25	3.66	3.58	3.35	3.78	1.06	1/2"-13	1.56	3000 (210)	80-90
2"	FFT34-200	1.69	3.06	3.81	4.02	4.02	3.94	4.13	1.22	1/2"-13	2.21	3000 (210)	80-90
2 1/2"	FFT34-250	2.00	3.50	4.28	4.49	4.49	4.37	4.61	1.40	1/2"-13	3.14	2500 (175)	80-90
3"	FFT34-300	2.44	4.19	5.16	5.28	5.35	5.24	5.39	1.67	5/8"-11	4.67	2000 (140)	110-120

FFT64 Flare Flange - SAE Code 62 With Tapped Holes

High Pressure Series 6000 PSI (420 bar)

Size	Flange Part No.	Dimensions (in)								Tap UNC-2B	WT. lbs/pc	Working Pressure PSI (bar)	Bolt Torque ft.lbs.
		A	B	G	H	M	N	P	E				
1/2"	FFT64-050	0.72	1.59	1.88	2.22	2.20	2.09	2.32	0.81	5/16"-18	0.56	6000 (420)	15-18
3/4"	FFT64-075	0.94	2.00	2.38	2.81	2.76	2.68	2.95	1.02	3/8"-16	1.03	6000 (420)	20-30
1"	FFT64-100	1.09	2.25	2.75	3.19	3.19	2.99	3.35	1.03	7/16"-14	1.39	6000 (420)	40-50
1 1/4"	FFT64-125	1.25	2.63	3.06	3.75	3.58	3.27	3.90	1.25	1/2"-13	2.09	6000 (420)	80-90
1 1/2"	FFT64-150	1.44	3.13	3.75	4.44	4.25	3.98	4.57	1.38	5/8"-11	3.85	6000 (420)	110-120
2"	FFT64-200	1.75	3.81	4.50	5.25	5.04	4.72	5.39	1.68	3/4"-10	6.04	6000 (420)	120-130

MATERIAL: FORGED CARBON STEEL, YELLOW ZINC DICHROMATE PLATED, (STAINLESS STEEL AVAILABLE)



Flare Flange

ISO 6164 - Flanges with Clearance Holes

To be used with
flared pipe only
Ref. pages B6-B7

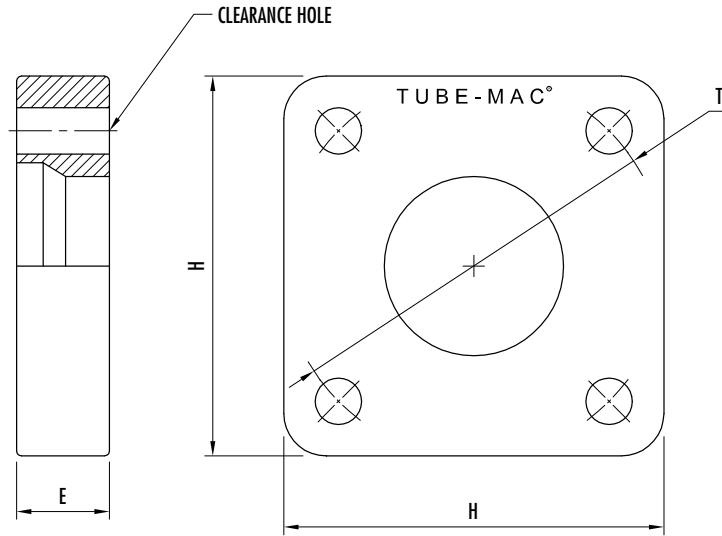

FFC74 Flare Flange - ISO 6164 With Clearance Holes

5800 PSI (400 bar)

Size	Flange Part No.	Dimensions (in)			Bolt Minimum Grade 5	WT. lbs/pc	Working Pressure PSI (bar)	Bolt Torque ft.lbs.
		T	H	E				
2 1/2"	FFC74-250	4.65	4.72	1.48	3/4" UNC	5.06	5800 (400)	120-130
3"	FFC74-300	5.71	5.91	1.73	1" UNC	8.79	5800 (400)	350-400

• FOR BOLT KITS - REFERENCE SECTION R

MATERIAL: CARBON STEEL, YELLOW ZINC DICHROMATE PLATED, (STAINLESS STEEL AVAILABLE)



Flare Flange

TMI® 9-Bolt - Flanges with Clearance Holes

To be used with
flared pipe only
Ref. pages B6-B7

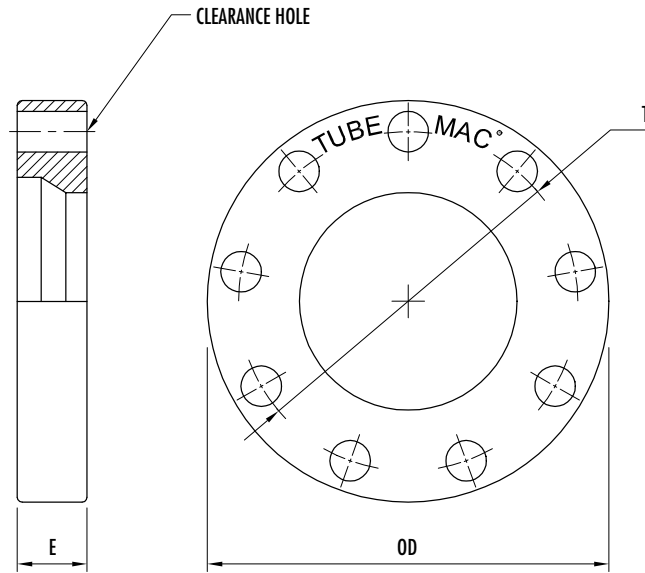

FFC49 Flare Flange - TMI® 9-Bolt With Clearance Holes

For use with Flared Connection to 9-Bolt Ball Valve **BBVG27** (Ref. page P10)
4100-4200 PSI (280-290 bar)

Size	Flange Part No.	Dimensions (in)			Bolt Minimum Grade 5	WT. lbs/pc	Working Pressure PSI (bar)	Bolt Torque ft.lbs.
		T	OD	E				
2 1/2"	FFC49-250	4.03	4.95	1.48	1/2" UNC	3.04	4200 (290)	80-90
3"	FFC49-300	5.49	6.50	1.73	5/8" UNC	6.01	4100 (280)	110-120

• FOR BOLT KITS - REFERENCE SECTION R

MATERIAL: CARBON STEEL, YELLOW ZINC DICHROMATE PLATED, (STAINLESS STEEL AVAILABLE)



Flare Flange Cones

'O' Ring Face

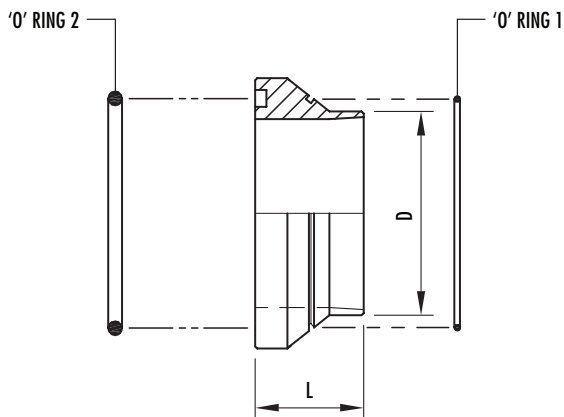
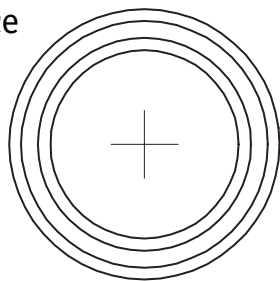

CO Cone - 'O' Ring Face

Complete With Buna 'O' Rings (Standard)

Schedule 40

Size	Cone Part No.	Dimensions (in)		'O' Ring 1 (Buna) Part No.	'O' Ring 2 (Buna) Part No.	WT. lbs/pc
		D	L			
1/2"	CO-SCH40-050-*	0.62	0.83	OR*-1915	OR*-2-210	0.10
3/4"	CO-SCH40-075-*	0.82	0.89	OR*-2515	OR*-2-214	0.12
1"	CO-SCH40-100-*	1.04	0.96	OR*-3015	OR*-2-219	0.20
1 1/4"	CO-SCH40-125-*	1.34	0.99	OR*-3815	OR*-2-222	0.25
1 1/2"	CO-SCH40-150-*	1.61	1.12	OR*-4315	OR*-2-225	0.41
2"	CO-SCH40-200-*	2.06	1.10	OR*-5615	OR*-2-228	0.47
2 1/2"	CO-SCH40-250-*	2.46	1.32	OR*-6515	OR*-2-232	0.99
3"	CO-SCH40-300-*	3.06	1.33	OR*-8015	OR*-2-237	1.33
4"	CO-SCH40-400-*	4.02	1.49	OR*-10615	OR*-2-245	1.80

Schedule 80

Size	Cone Part No.	Dimensions (in)		'O' Ring 1 (Buna) Part No.	'O' Ring 2 (Buna) Part No.	WT. lbs/pc
		D	L			
1/2"	CO-SCH80-050-*	0.54	0.83	OR*-1715	OR*-2-210	0.09
3/4"	CO-SCH80-075-*	0.74	0.90	OR*-2315	OR*-2-214	0.12
1"	CO-SCH80-100-*	0.95	0.97	OR*-2815	OR*-2-219	0.21
1 1/4"	CO-SCH80-125-*	1.27	0.99	OR*-3815	OR*-2-222	0.24
1 1/2"	CO-SCH80-150-*	1.50	1.13	OR*-4315	OR*-2-225	0.42
2"	CO-SCH80-200-*	1.93	1.10	OR*-5615	OR*-2-228	0.49
2 1/2"	CO-SCH80-250-*	2.32	1.32	OR*-6515	OR*-2-232	0.99
3"	CO-SCH80-300-*	2.89	1.26	OR*-8015	OR*-2-237	1.21
4"	CO-SCH80-400-*	3.82	1.62	OR*-10615	OR*-2-245	2.17

Schedule 160

Size	Cone Part No.	Dimensions (in)		'O' Ring 1 (Buna) Part No.	'O' Ring 2 (Buna) Part No.	WT. lbs/pc
		D	L			
1 1/2"	CO-SCH160-150-*	1.31	1.20	OR*-3815	OR*-2-225	0.42
2"	CO-SCH160-200-*	1.66	1.26	OR*-5015	OR*-2-228	0.67
2 1/2"	CO-SCH160-250-*	2.12	1.62	OR*-6515	OR*-2-232	1.42

* INSERT ' V ' TO INDICATE OPTIONAL VITON 'O' RINGS

MATERIAL: CARBON STEEL, YELLOW ZINC DICHROMATE PLATED, (STAINLESS STEEL STANDARD-316 AVAILABLE)



Flare Flange Cones

Flat Face

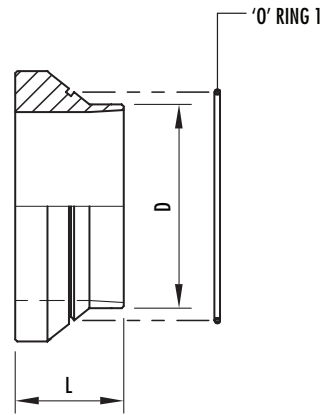
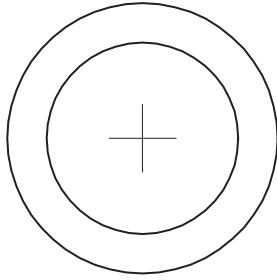

CF Cone - Flat Face

Complete With Buna 'O' Ring (Standard)

Schedule 40

Size	Cone Part No.	Dimensions (in)		'O' Ring 1 (Buna) Part No.	WT. lbs/pc
		D	L		
1/2"	CF-SCH40-050-*	0.62	0.83	OR*-1915	0.11
3/4"	CF-SCH40-075-*	0.82	0.89	OR*-2515	0.14
1"	CF-SCH40-100-*	1.04	0.96	OR*-3015	0.23
1 1/4"	CF-SCH40-125-*	1.34	0.99	OR*-3815	0.27
1 1/2"	CF-SCH40-150-*	1.61	1.12	OR*-4315	0.45
2"	CF-SCH40-200-*	2.06	1.10	OR*-5615	0.52
2 1/2"	CF-SCH40-250-*	2.46	1.32	OR*-6515	1.01
3"	CF-SCH40-300-*	3.06	1.33	OR*-8015	1.39
4"	CF-SCH40-400-*	4.02	1.49	OR*-10615	1.90

Schedule 80

Size	Cone Part No.	Dimensions (in)		'O' Ring 1 (Buna) Part No.	WT. lbs/pc
		D	L		
1/2"	CF-SCH80-050-*	0.54	0.83	OR*-1715	0.10
3/4"	CF-SCH80-075-*	0.74	0.90	OR*-2315	0.14
1"	CF-SCH80-100-*	0.95	0.97	OR*-2815	0.23
1 1/4"	CF-SCH80-125-*	1.27	0.99	OR*-3815	0.27
1 1/2"	CF-SCH80-150-*	1.50	1.13	OR*-4315	0.46
2"	CF-SCH80-200-*	1.93	1.10	OR*-5615	0.53
2 1/2"	CF-SCH80-250-*	2.32	1.32	OR*-6515	1.06
3"	CF-SCH80-300-*	2.89	1.26	OR*-8015	1.28
4"	CF-SCH80-400-*	3.82	1.62	OR*-106151	2.20

Schedule 160

Size	Cone Part No.	Dimensions (in)		'O' Ring 1 (Buna) Part No.	WT. lbs/pc
		D	L		
1 1/2"	CF-SCH160-150-*	1.31	1.20	OR*-3815	0.45
2"	CF-SCH160-200-*	1.66	1.26	OR*-5015	0.71
2 1/2"	CF-SCH160-250-*	2.12	1.62	OR*-6515	1.50

* INSERT ' V ' TO INDICATE OPTIONAL VITON 'O' RING

MATERIAL: CARBON STEEL, BLACK ZINC DICHROMATE PLATED, (STAINLESS STEEL STANDARD-316 AVAILABLE)



Flare Flange Cones

'O' Ring Face With Pilot Port

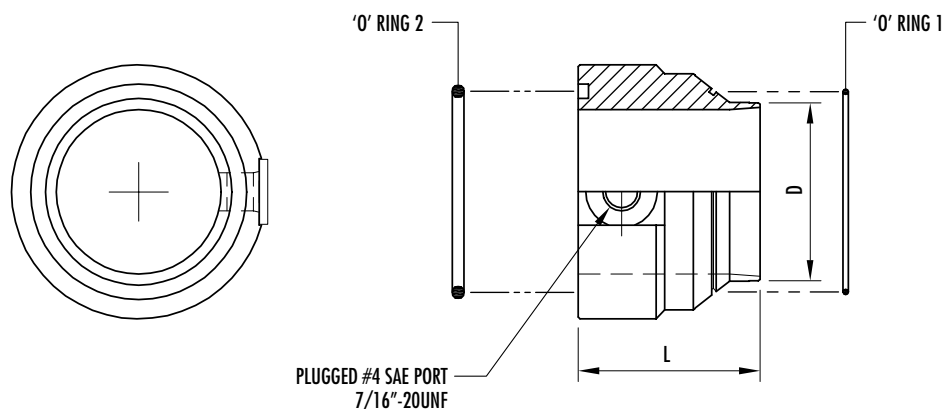

COP Cone - 'O' Ring Face With Pilot Port

Complete With Buna 'O' Rings (Standard) and #4 SAE Port (Plugged)

Schedule 40

Size	Cone Part No.	Dimensions (in)		'O' Ring 1 (Buna) Part No.	'O' Ring 2 (Buna) Part No.	WT. lbs/pc
		D	L			
1/2"	COP-SCH40-050-*	0.62	1.83	OR*-1915	OR*-2-210	0.16
3/4"	COP-SCH40-075-*	0.82	1.89	OR*-2515	OR*-2-214	0.20
1"	COP-SCH40-100-*	1.04	1.96	OR*-3015	OR*-2-219	0.41
1 1/4"	COP-SCH40-125-*	1.34	1.99	OR*-3815	OR*-2-222	0.43
1 1/2"	COP-SCH40-150-*	1.61	2.12	OR*-4315	OR*-2-225	0.73
2"	COP-SCH40-200-*	2.06	2.10	OR*-5615	OR*-2-228	0.82
2 1/2"	COP-SCH40-250-*	2.46	2.32	OR*-6515	OR*-2-232	2.60
3"	COP-SCH40-300-*	3.06	2.33	OR*-8015	OR*-2-237	3.66

Schedule 80

Size	Cone Part No.	Dimensions (in)		'O' Ring 1 (Buna) Part No.	'O' Ring 2 (Buna) Part No.	WT. lbs/pc
		D	L			
1/2"	COP-SCH80-050-*	0.54	1.83	OR*-1715	OR*-2-210	0.16
3/4"	COP-SCH80-075-*	0.74	1.90	OR*-2315	OR*-2-214	0.21
1"	COP-SCH80-100-*	0.95	1.97	OR*-2815	OR*-2-219	0.36
1 1/4"	COP-SCH80-125-*	1.27	1.99	OR*-3815	OR*-2-222	0.43
1 1/2"	COP-SCH80-150-*	1.50	2.13	OR*-4315	OR*-2-225	0.75
2"	COP-SCH80-200-*	1.93	2.10	OR*-5615	OR*-2-228	0.81
2 1/2"	COP-SCH80-250-*	2.32	2.32	OR*-6515	OR*-2-232	1.78
3"	COP-SCH80-300-*	2.89	2.26	OR*-8015	OR*-2-237	2.19

* INSERT ' V ' TO INDICATE OPTIONAL VITON 'O' RINGS AND 'O' RING FOR #4 SAE PLUG

MATERIAL: CARBON STEEL, YELLOW ZINC DICHROMATE PLATED, (STAINLESS STEEL STANDARD-316 AVAILABLE)



Flare Flange Cones

Flat Face With Pilot Port

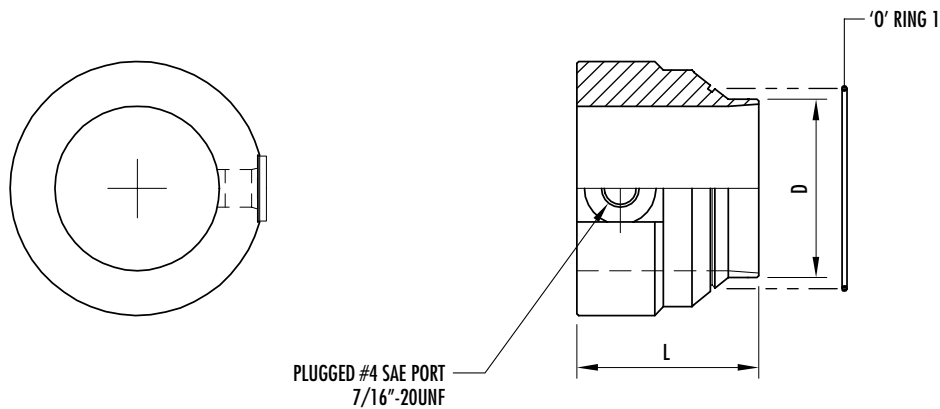

CFP Cone - Flat Face With Pilot Port

Complete With Buna 'O' Ring (Standard) and #4 SAE Port (Plugged)

Schedule 40

Size	Cone Part No.	Dimensions (in)		'O' Ring 1 (Buna) Part No.	WT. lbs/pc
		D	L		
1/2"	CFP-SCH40-050-*	0.62	1.83	OR*-1915	0.16
3/4"	CFP-SCH40-075-*	0.82	1.89	OR*-2515	0.20
1"	CFP-SCH40-100-*	1.04	1.96	OR*-3015	0.41
1 1/4"	CFP-SCH40-125-*	1.34	1.99	OR*-3815	0.43
1 1/2"	CFP-SCH40-150-*	1.61	2.12	OR*-4315	0.73
2"	CFP-SCH40-200-*	2.06	2.10	OR*-5615	0.82
2 1/2"	CFP-SCH40-250-*	2.46	2.32	OR*-6515	2.78
3"	CFP-SCH40-300-*	3.06	2.33	OR*-8015	3.86

Schedule 80

Size	Cone Part No.	Dimensions (in)		'O' Ring 1 (Buna) Part No.	WT. lbs/pc
		D	L		
1/2"	CFP-SCH80-050-*	0.54	1.83	OR*-1715	0.16
3/4"	CFP-SCH80-075-*	0.74	1.90	OR*-2315	0.21
1"	CFP-SCH80-100-*	0.95	1.97	OR*-2815	0.36
1 1/4"	CFP-SCH80-125-*	1.27	1.99	OR*-3815	0.43
1 1/2"	CFP-SCH80-150-*	1.50	2.13	OR*-4315	0.75
2"	CFP-SCH80-200-*	1.93	2.10	OR*-5615	0.81
2 1/2"	CFP-SCH80-250-*	2.32	2.32	OR*-6515	1.78
3"	CFP-SCH80-300-*	2.89	2.26	OR*-8015	2.19

* INSERT ' V ' TO INDICATE OPTIONAL VITON 'O' RING AND 'O' RING FOR #4 SAE PLUG

MATERIAL: CARBON STEEL, BLACK ZINC DICHROMATE PLATED, (STAINLESS STEEL STANDARD-316 AVAILABLE)



Flare Flanges - Reducing

SAE - Flanges with Clearance Holes

To be used with
flared pipe only
Ref. pages B6-B7

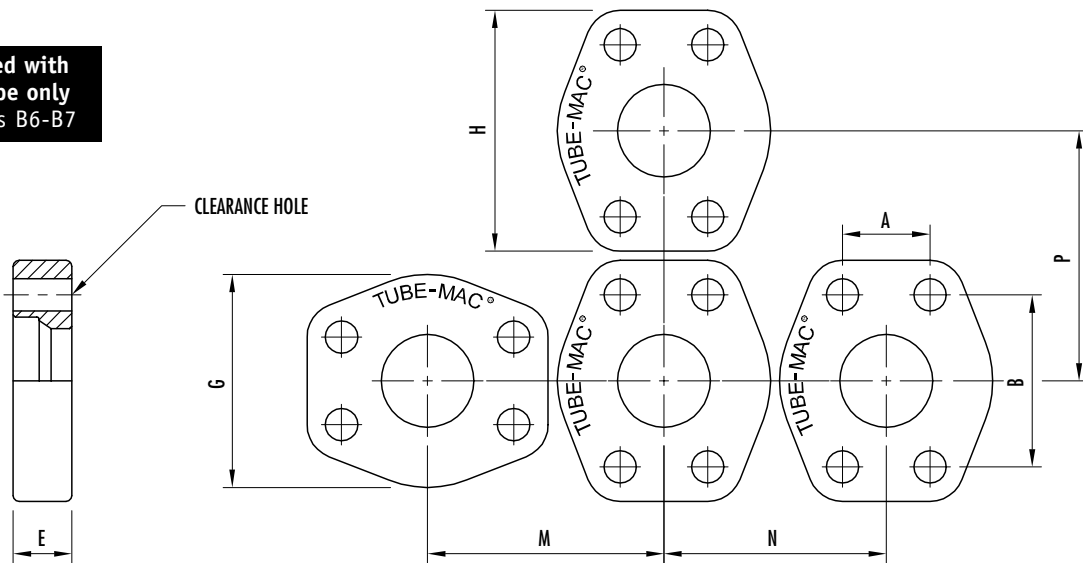

FFCR34 Reducing Flare Flange - SAE Code 61 With Clearance Holes

Standard Pressure Series 2000-5000 PSI (140-350 bar)

Size (flange x pipe)	Reducing Flange Part No.	Dimensions (in)								Bolt Minimum Grade 5	WT. lbs/pc	Working Pressure PSI (bar)	Bolt Torque ft.lbs.
		A	B	G	H	M	N	P	E				
3/4" x 1/2"	FFCR34-075 x 050	0.88	1.88	2.06	2.56	2.40	2.17	2.68	0.82	3/8" UNC	0.74	5000 (350)	20-30
1" x 3/4"	FFCR34-100 x 075	1.03	2.06	2.31	2.76	2.64	2.44	2.87	0.87	3/8" UNC	0.77	5000 (350)	20-30
1 1/4" x 1"	FFCR34-125 x 100	1.19	2.31	2.88	3.11	3.11	2.99	3.23	0.91	7/16" UNC	1.01	4000 (275)	40-50
1 1/2" x 1 1/4"	FFCR34-150 x 125	1.41	2.75	3.25	3.66	3.58	3.35	3.78	1.06	1/2" UNC	1.76	3000 (210)	80-90
2" x 1 1/2"	FFCR34-200 x 150	1.69	3.06	3.81	4.02	4.02	3.94	4.13	1.22	1/2" UNC	2.41	3000 (210)	80-90
2 1/2" x 2"	FFCR34-250 x 200	2.00	3.50	4.28	4.49	4.49	4.37	4.61	1.40	1/2" UNC	3.54	2500 (175)	80-90
3" x 2 1/2"	FFCR34-300 x 250	2.44	4.19	5.16	5.28	5.35	5.24	5.39	1.67	5/8" UNC	5.37	2000 (140)	110-120

FFCR64 Reducing Flare Flange - SAE Code 62 With Clearance Holes

High Pressure Series 6000 PSI (420 bar)

Size (flange x pipe)	Reducing Flange Part No.	Dimensions (in)								Bolt Minimum Grade 5	WT. lbs/pc	Working Pressure PSI (bar)	Bolt Torque ft.lbs.
		A	B	G	H	M	N	P	E				
3/4" x 1/2"	FFCR64-075 x 050	0.94	2.00	2.38	2.81	2.76	2.68	2.95	1.02	3/8" UNC	1.14	6000 (420)	20-30
1" x 3/4"	FFCR64-100 x 075	1.09	2.25	2.75	3.19	3.19	2.99	3.35	1.03	7/16" UNC	1.48	6000 (420)	40-50
1 1/4" x 1"	FFCR64-125 x 100	1.25	2.63	3.06	3.75	3.58	3.27	3.90	1.25	1/2" UNC	2.20	6000 (420)	80-90
1 1/2" x 1 1/4"	FFCR64-150 x 125	1.44	3.13	3.75	4.44	4.25	3.98	4.57	1.38	5/8" UNC	4.05	6000 (420)	110-120
2" x 1 1/2"	FFCR64-200 x 150	1.75	3.81	4.50	5.25	5.04	4.72	5.39	1.68	3/4" UNC	6.24	6000 (420)	120-130

- FOR BOLT KITS - REFERENCE SECTION R
- OTHER REDUCER SIZES ARE AVAILABLE
- TO ORDER COMPLETE ASSEMBLIES REFERENCE PAGES B20-B25

MATERIAL: FORGED CARBON STEEL, YELLOW ZINC DICHROMATE PLATED, (STAINLESS STEEL AVAILABLE)



Flare Flange Cones - Reducing

'O' Ring Face

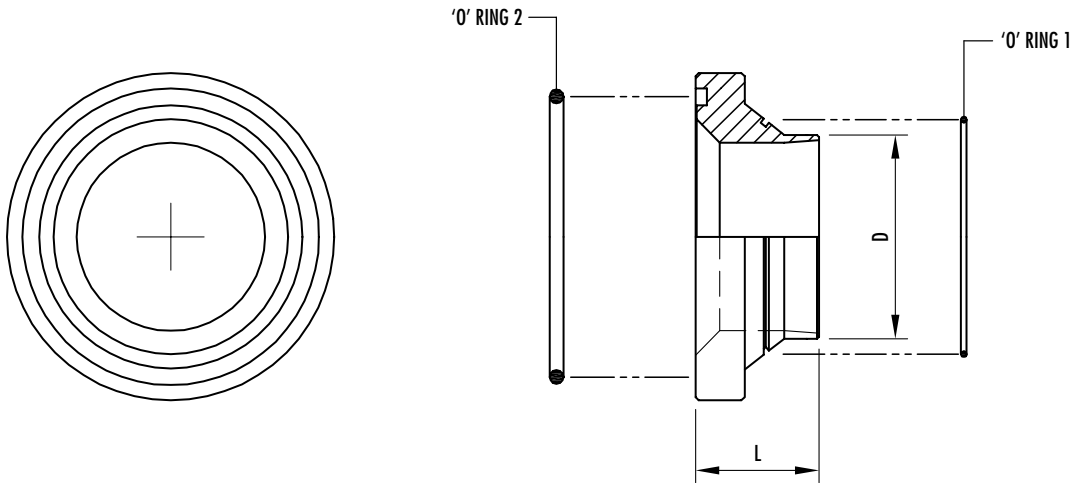

COR Reducing Cone - 'O' Ring Face

Complete With Buna 'O' Rings (Standard)

Schedule 40

Size (flange x pipe)	Reducing Cone Part No.	Dimensions (in)		'O' Ring 1 (Buna) Part No.	'O' Ring 2 (Buna) Part No.	WT. lbs/pc
		D	L			
3/4" x 1/2"	COR-SCH40-075 x 050-*	0.62	0.89	OR*-1915	OR*-2-214	0.15
1" x 3/4"	COR-SCH40-100 x 075-*	0.82	0.96	OR*-2515	OR*-2-219	0.25
1 1/4" x 1"	COR-SCH40-125 x 100-*	1.04	0.99	OR*-3015	OR*-2-222	0.34
1 1/2" x 1 1/4"	COR-SCH40-150 x 125-*	1.34	1.12	OR*-3815	OR*-2-225	0.51
2" x 1 1/2"	COR-SCH40-200 x 150-*	1.61	1.10	OR*-4315	OR*-2-228	0.59
2 1/2" x 2"	COR-SCH40-250 x 200-*	2.06	1.32	OR*-5715	OR*-2-232	1.17
3" x 2 1/2"	COR-SCH40-300 x 250-*	2.46	1.33	OR*-6515	OR*-2-237	1.59

Schedule 80

Size (flange x pipe)	Reducing Cone Part No.	Dimensions (in)		'O' Ring 1 (Buna) Part No.	'O' Ring 2 (Buna) Part No.	WT. lbs/pc
		D	L			
3/4" x 1/2"	COR-SCH80-075 x 050-*	0.54	0.90	OR*-1715	OR*-2-214	0.16
1" x 3/4"	COR-SCH80-100 x 075-*	0.74	0.97	OR*-2315	OR*-2-219	0.27
1 1/4" x 1"	COR-SCH80-125 x 100-*	0.95	0.99	OR*-2815	OR*-2-222	0.37
1 1/2" x 1 1/4"	COR-SCH80-150 x 125-*	1.27	1.13	OR*-3815	OR*-2-225	0.56
2" x 1 1/2"	COR-SCH80-200 x 150-*	1.50	1.10	OR*-4315	OR*-2-228	0.66
2 1/2" x 2"	COR-SCH80-250 x 200-*	1.93	1.32	OR*-5715	OR*-2-232	1.24
3" x 2 1/2"	COR-SCH80-300 x 250-*	2.32	1.26	OR*-6515	OR*-2-237	1.68

* INSERT ' V ' TO INDICATE OPTIONAL VITON 'O' RINGS

• OTHER REDUCER SIZES ARE AVAILABLE

MATERIAL: CARBON STEEL, YELLOW ZINC DICHROMATE PLATED, (STAINLESS STEEL STANDARD-316 AVAILABLE)



Flare Flanges - Reducing

SAE - Flanges with Tapped Holes

To be used with
flared pipe only
Ref. pages B6-B7

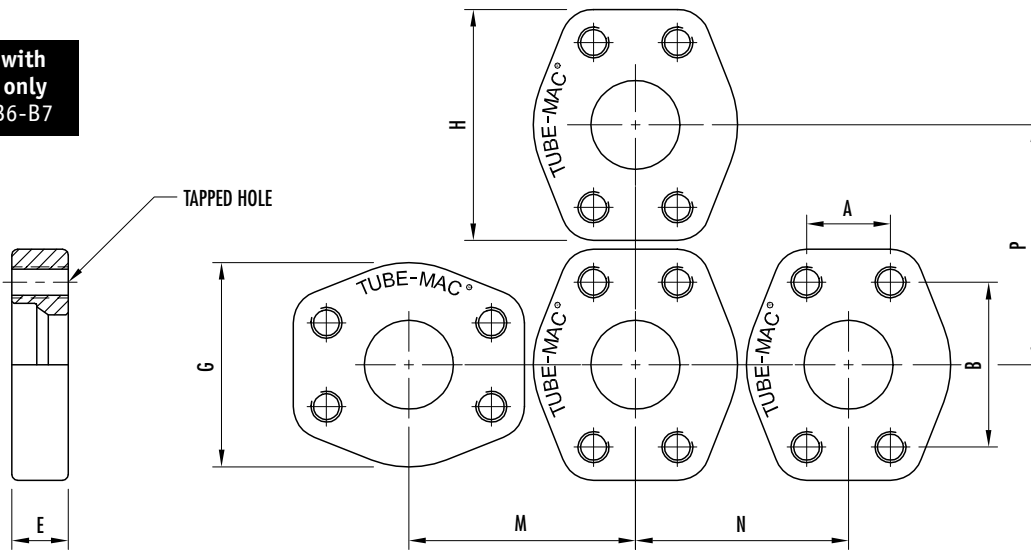

FFTR34 Reducing Flare Flange - SAE Code 61 With Tapped Holes

Standard Pressure Series 2000-5000 PSI (140-350 bar)

Size (flange x pipe)	Reducing Flange Part No.	Dimensions (in)								Bolt Minimum Grade 5	WT. lbs/pc	Working Pressure PSI (bar)	Bolt Torque ft.lbs.
		A	B	G	H	M	N	P	E				
3/4" x 1/2"	FFTR34-075 x 050	0.88	1.88	2.06	2.56	2.40	2.17	2.68	0.82	3/8"-16	0.74	5000 (350)	20-30
1" x 3/4"	FFTR34-100 x 075	1.03	2.06	2.31	2.76	2.64	2.44	2.87	0.87	3/8"-16	0.77	5000 (350)	20-30
1 1/4" x 1"	FFTR34-125 x 100	1.19	2.31	2.88	3.11	3.11	2.99	3.23	0.91	7/16"-14	1.01	4000 (275)	40-50
1 1/2" x 1 1/4"	FFTR34-150 x 125	1.41	2.75	3.25	3.66	3.58	3.35	3.78	1.06	1/2"-13	1.76	3000 (210)	80-90
2" x 1 1/2"	FFTR34-200 x 150	1.69	3.06	3.81	4.02	4.02	3.94	4.13	1.22	1/2"-13	2.41	3000 (210)	80-90
2 1/2" x 2"	FFTR34-250 x 200	2.00	3.50	4.28	4.49	4.49	4.37	4.61	1.40	1/2"-13	3.54	2500 (175)	80-90
3" x 2 1/2"	FFTR34-300 x 250	2.44	4.19	5.16	5.28	5.35	5.24	5.39	1.67	5/8"-11	5.37	2000 (140)	110-120

FFTR64 Reducing Flare Flange - SAE Code 62 With Tapped Holes

High Pressure Series 6000 PSI (420 bar)

Size (flange x pipe)	Reducing Flange Part No.	Dimensions (in)								Bolt Minimum Grade 5	WT. lbs/pc	Working Pressure PSI (bar)	Bolt Torque ft.lbs.
		A	B	G	H	M	N	P	E				
3/4" x 1/2"	FFTR64-075 x 050	0.94	2.00	2.38	2.81	2.76	2.68	2.95	1.02	3/8"-16	1.14	6000 (420)	20-30
1" x 3/4"	FFTR64-100 x 075	1.09	2.25	2.75	3.19	3.19	2.99	3.35	1.03	7/16"-14	1.48	6000 (420)	40-50
1 1/4" x 1"	FFTR64-125 x 100	1.25	2.63	3.06	3.75	3.58	3.27	3.90	1.25	1/2"-13	2.20	6000 (420)	80-90
1 1/2" x 1 1/4"	FFTR64-150 x 125	1.44	3.13	3.75	4.44	4.25	3.98	4.57	1.38	5/8"-11	4.05	6000 (420)	110-120
2" x 1 1/2"	FFTR64-200 x 150	1.75	3.81	4.50	5.25	5.04	4.72	5.39	1.68	3/4"-10	6.24	6000 (420)	120-130

- FOR BOLT KITS - REFERENCE SECTION R
- OTHER REDUCER SIZES ARE AVAILABLE
- TO ORDER COMPLETE ASSEMBLIES REFERENCE PAGES B20-B25

MATERIAL: FORGED CARBON STEEL, YELLOW ZINC DICHROMATE PLATED, (STAINLESS STEEL AVAILABLE)



Flare Flange Cones - Reducing

Flat Face

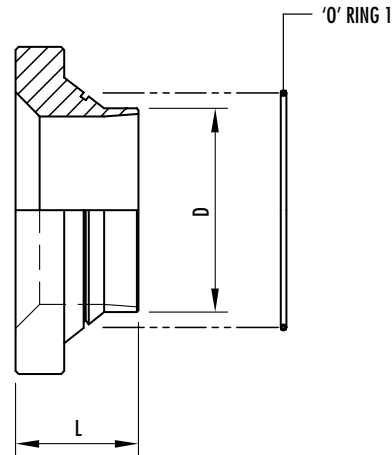
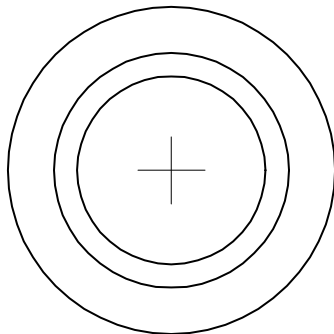

CFR Reducing Cone - Flat Face

Complete With Buna 'O' Ring (Standard)

Schedule 40

Size (flange x pipe)	Reducing Cone Part No.	Dimensions (in)		'O' Ring 1 (Buna) Part No.	WT. lbs/pc
		D	L		
3/4" x 1/2"	CFR-SCH40-075 x 050-*	0.62	0.89	OR*-1915	0.17
1" x 3/4"	CFR-SCH40-100 x 075-*	0.82	0.96	OR*-2515	0.28
1 1/4" x 1"	CFR-SCH40-125 x 100-*	1.04	0.99	OR*-3015	0.37
1 1/2" x 1 1/4"	CFR-SCH40-150 x 125-*	1.34	1.12	OR*-3815	0.55
2" x 1 1/2"	CFR-SCH40-200 x 150-*	1.61	1.10	OR*-4315	0.64
2 1/2" x 2"	CFR-SCH40-250 x 200-*	2.06	1.32	OR*-5715	1.22
3" x 2 1/2"	CFR-SCH40-300 x 250-*	2.46	1.33	OR*-6515	1.65

Schedule 80

Size (flange x pipe)	Reducing Cone Part No.	Dimensions (in)		'O' Ring 1 (Buna) Part No.	WT. lbs/pc
		D	L		
3/4" x 1/2"	CFR-SCH80-075 x 050-*	0.54	0.90	OR*-1715	0.18
1" x 3/4"	CFR-SCH80-100 x 075-*	0.74	0.97	OR*-2315	0.30
1 1/4" x 1"	CFR-SCH80-125 x 100-*	0.95	0.99	OR*-2815	0.40
1 1/2" x 1 1/4"	CFR-SCH80-150 x 125-*	1.27	1.13	OR*-3815	0.60
2" x 1 1/2"	CFR-SCH80-200 x 150-*	1.50	1.10	OR*-4315	0.71
2 1/2" x 2"	CFR-SCH80-250 x 200-*	1.93	1.32	OR*-5715	1.28
3" x 2 1/2"	CFR-SCH80-300 x 250-*	2.32	1.26	OR*-6515	1.74

* INSERT ' V ' TO INDICATE OPTIONAL VITON 'O' RING

• OTHER REDUCER SIZES ARE AVAILABLE

MATERIAL: CARBON STEEL, BLACK ZINC DICHROMATE PLATED, (STAINLESS STEEL STANDARD-316 AVAILABLE)



Flare Flange Pipe Assembly

Typical PAF Assembly

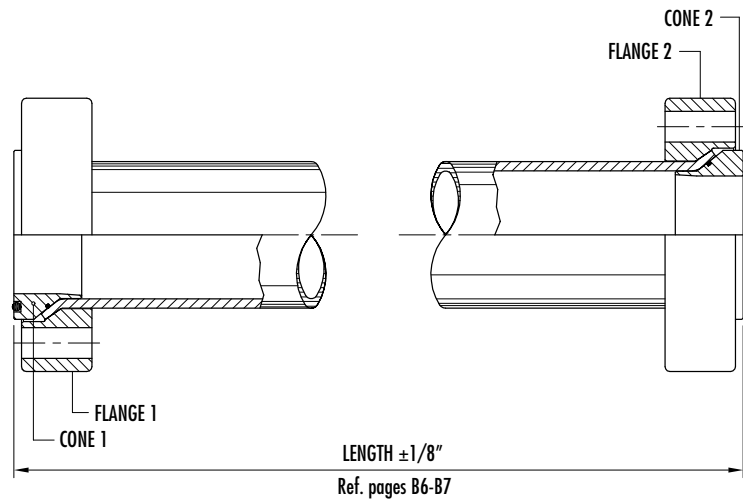

COMPLETE ASSEMBLY CONSISTS OF:

- ONE (1) LENGTH OF CLEAN PIPE
(REF. PAGES B6-B7)
- TWO (2) FLARE FLANGES (REF. PAGES B8-B11)
- TWO (2) CONES
(REF. PGS B12-B15 FOR TYPE OF CONE)
- ENDS SEALED WITH 6 MIL HEAT SHRINK MATERIAL

PART NO. (EXAMPLE): PAF/52 - SCH40-050 - FC34 - FC34 - CO - CF - 240

• REDUCING FLANGES AND CONES ARE AVAILABLE (REFERENCE PAGES B16-B19)

FOR FLARE FLANGE ASSEMBLIES UTILIZING REDUCING FLANGES AND CONES ADD (R) TO FLANGE AND CONE CODE NUMBERS.
ie. SAE code 61 flare flange with clearance holes - code number FC34 would be FCR34-(flange size)

REDUCING PART NO. (EXAMPLE): PAF/52 - SCH40-050 - FCR34-075 - FC34 - COR - CF - 240

Consult factory for ordering assistance



Flare Flange Pipe Assembly

Complete Assembly Part Number

		Code	PAF /	Pipe & Cone Material	Pipe Size & Schedule	Flange 1	Flange 2	Cone 1	Cone 2	Length	Options	
Pipe Assembly - Flared		PAF										
Pipe & Cone Material Carbon Steel Ref. page B6	TMP52CD	52										
	♦♦TMP44HR	44										
	♦TMP46CD	46										
Pipe & Cone Material Stainless Steel Ref. page B7	TMP304SS	304										
	TMP316SS	316										
	♦TMP2205SS	2205										
Pipe Size & Schedule	1/2"	SCH40-050 SCH80-050										
	3/4"	SCH40-075 SCH80-075										
	1"	SCH40-100 SCH80-100										
	1 1/4"	SCH40-125 SCH80-125										
	1 1/2"	SCH40-150 SCH80-150										
	2"	SCH40-200 SCH80-200										
	2 1/2"	SCH40-250 SCH80-250										
	3"	SCH40-300 SCH80-300										
	Flange Type Carbon Steel Yellow Zinc Dicromate Plated Ref. pages (B8-B11)	FFC34 SAE Code 61 W/Clearance Holes	FC34									
		*FFT34 SAE Code 61 W/Tapped Holes	FT34									
FFC64 SAE Code 62 W/Clearance Holes		FC64										
*FFT64 SAE Code 62 W/Tapped Holes		FT64										
FFC74 ISO 6164 W/Clearance Holes		FC74										
**FFC49 TMI® 9-Bolt W/Clearance Holes		FC49										
Cone Type Ref. pages (B12-B15)	Cone - Flat Face	CF										
	Cone - 'O' Ring Face	CO										
Length	Specify (in.)											
Options	Viton	V										
	Painted (Specify)	P										
Complete Stainless Steel Assembly: (including flanges)	SS											

♦♦TMP44HR PIPE IS ONLY AVAILABLE IN 2 1/2" & 3" SCHEDULE 40 SIZES

♦ TMP46CD PIPE IS ONLY AVAILABLE IN 1 1/4"-2" SCHEDULE 80 SIZES

TMP2205SS PIPE IS ONLY AVAILABLE IN 1 1/4"-2" SCHEDULE 80 SIZES

**FOR USE ONLY WITH 9-BOLT BALL VALVE CONNECTION (REF. PAGE P10)

* NORMALLY USED FOR CONNECTION TO SPLIT FLANGE TYPE ENDS

PART NO. (EXAMPLE): PAF/52 - SCH40-050 - FC34 - FC34 - CO - CF - 240

- ASSEMBLY WORKING PRESSURE RATINGS ARE SUBJECT TO THE LESSER OF THE FLANGE OR PIPE RATINGS
- SEE REFERENCE PAGES INDICATED ABOVE FOR PRESSURE RATINGS
- FOR BOLT KITS - REFERENCE SECTION R



Flare Flange Bent Pipe Assembly

Typical BPAF Assembly

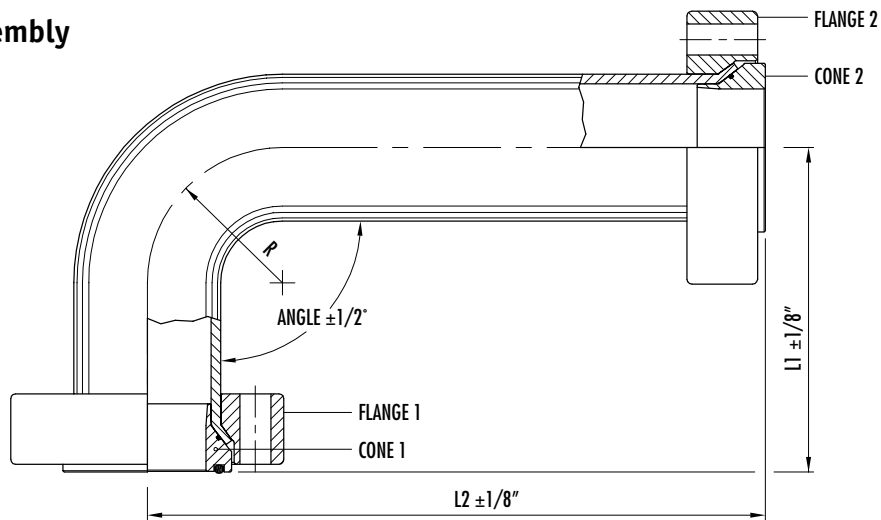

COMPLETE ASSEMBLY CONSISTS OF:

- ONE (1) LENGTH OF BENT CLEAN PIPE (REF. PAGES B6-B7)
- TWO (2) FLARE FLANGES (REF. PAGES B8-B11)
- TWO (2) CONES (REF. PGS B12-B15 FOR TYPE OF CONE)
- ENDS SEALED WITH 6 MIL HEAT SHRINK MATERIAL

PART NO. (EXAMPLE): BPAF/52 - SCH80-100 - FC34 - FC34 - CO - CF - R1 - 125 - 90 - 115

Size	R1		R2	
	Field Manufactured		Factory Manufactured	
	Dimensions (in)		Dimensions (in)	
	L(min.)	R	L(min.)	R**
1/2"	6.00	3.875	5.00	2.625
3/4"	6.50	4.281	5.00	3.125
1"	7.00	4.875	5.00	2.625
1 1/4"	8.50	5.625	6.00	3.375
1 1/2"	11.50	8.188	6.50	3.815
2"	13.00	9.438	8.00	4.750
2 1/2"	16.00	12.500	11.00	7.500
3"	19.00	15.000	12.50	9.000

**OTHER RADII AVAILABLE (CONSULT FACTORY)

- FOR BOLT KITS - REFERENCE SECTION R

MATERIAL: CARBON STEEL, YELLOW ZINC DICHROMATE PLATED, (STAINLESS STEEL AVAILABLE)

- **REDUCING FLANGES AND CONES ARE AVAILABLE (REFERENCE PAGES B16-B19)**

FOR FLARE FLANGE ASSEMBLIES UTILIZING REDUCING FLANGES AND CONES ADD (R) TO FLANGE AND CONE CODE NUMBERS.
ie. SAE code 61 flare flange with clearance holes - code number FC34 would be FCR34-(flange size)

REDUCING PART NO. (EXAMPLE): BPAF/52 - SCH80-100 - FCR34-125 - FC34 - COR - CF - R1 - 125 - 90 - 115

Consult factory for ordering assistance



Flare Flange Bent Pipe Assembly

Complete Assembly Part Number

		Code	BPAF	Pipe & Cone Material	Pipe Size & Schedule	Flange 1	Flange 2	Cone 1	Cone 2	Radius	Length L1	Angle	Length L2	Options
Bent Pipe Assembly - Flared		BPAF												
Pipe & Cone Material Carbon Steel Ref. page B6	TMP52CD	52												
	♦♦ TMP44HR	44												
	♦ TMP46CD	46												
Pipe & Cone Material Stainless Steel Ref. page B7	TMP304SS	304												
	TMP316SS	316												
	♦ TMP2205SS	2205												
Pipe Size & Schedule	1/2"	SCH40-050 SCH80-050												
	3/4"	SCH40-075 SCH80-075												
	1"	SCH40-100 SCH80-100												
	1 1/4"	SCH40-125 SCH80-125												
	1 1/2"	SCH40-150 SCH80-150												
	2"	SCH40-200 SCH80-200												
	2 1/2"	SCH40-250 SCH80-250												
	3"	SCH40-300 SCH80-300												
	Flange Type Carbon Steel Yellow Zinc Dicromate Plated Ref. pages (B8-B11)	FFC34 SAE Code 61 W/Clearance Holes	FC34											
* FFT34 SAE Code 61 W/Tapped Holes		FT34												
FFC64 SAE Code 62 W/Clearance Holes		FC64												
* FFT64 SAE Code 62 W/Tapped Holes		FT64												
FFC74 ISO 6164 W/Clearance Holes		FC74												
** FFC49 TMI® 9-Bolt W/Clearance Holes		FC49												
Cone Type Ref. pages (B12-B15)	Cone - Flat Face	CF												
	Cone - 'O' Ring Face	CO												
Radius Ref. page (B22)	Field Manufactured	R1												
	Factory Manufactured	R2												
Length	L1	Specify (in.)												
Angle	Max. 90°	Specify (°)												
Length	L2	Specify (in.)												
Options	Viton	V												
	Painted (Specify)	P												
Complete Stainless Steel Assembly: (including flanges)		SS												

♦♦TMP44HR PIPE IS ONLY AVAILABLE IN 2 1/2" & 3" SCHEDULE 40 SIZES

♦ TMP46CD PIPE IS ONLY AVAILABLE IN 1 1/4"-2" SCHEDULE 80 SIZES

TMP2205SS PIPE IS ONLY AVAILABLE IN 1 1/4"-2" SCHEDULE 80 SIZES

**FOR USE ONLY WITH 9-BOLT BALL VALVE CONNECTION (REFERENCE PAGE P10)

* NORMALLY USED FOR CONNECTION TO SPLIT FLANGE TYPE ENDS

PART NO. (EXAMPLE): BPAF/52 - SCH80-100 - FC34 - FC34 - CO - CF - R1 - 125 - 90 - 115

- ASSEMBLY WORKING PRESSURE RATINGS ARE SUBJECT TO THE LESSER OF THE FLANGE OR PIPE RATINGS
- SEE REFERENCE PAGES INDICATED ABOVE FOR PRESSURE RATINGS
- FOR BOLT KITS - REFERENCE SECTION R



Flare Flange Elbow Assembly

Short Radius Bent Elbow

Typical A/FFE Assembly

For field bent pipe assemblies
Ref. page B22

COMPLETE ASSEMBLY CONSISTS OF:

- FLARE FLANGE 90° ELBOW BODY
- TWO (2) FLARE FLANGES (REF. PAGES B8-B11)
- TWO (2) CONES
(REF. PAGES B12-B15 FOR TYPE OF CONE)
- ENDS SEALED WITH 6 MIL HEAT SHRINK MATERIAL

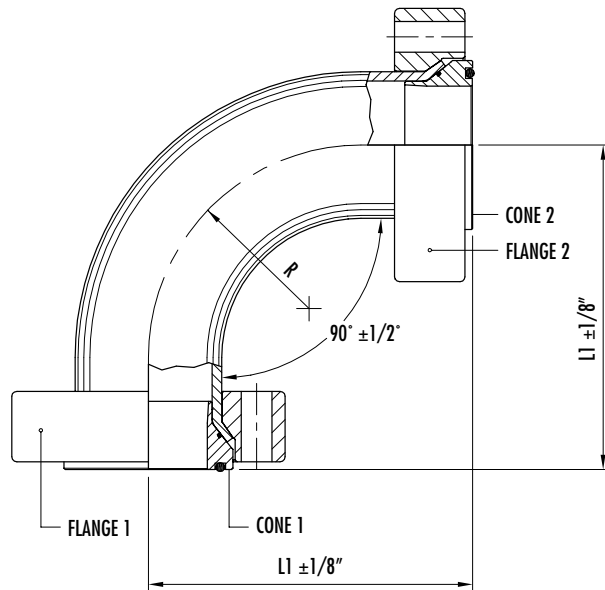

PART NO. (EXAMPLE): A/FFE - SCH40-050 - FC34 - FC34 - CO - CO

FFE Flare Flange Elbow Body

Size	Dimensions (in)		WT. *(Body Only) lbs/pc		Working Pressure *(Body Only) PSI (bar)	
	L1	R	SCH 40	SCH 80	SCH 40	SCH 80
1/2"	5.00	2.625	0.63	0.81	6000 (420)	6000 (420)
3/4"	5.00	3.125	0.81	1.06	5000 (350)	6000 (420)
1"	5.00	2.625	1.24	1.60	4700 (325)	6000 (420)
1 1/4"	6.00	3.375	2.00	2.63	3900 (270)	6000 (420)
1 1/2"	6.50	3.815	2.57	3.45	3500 (240)	6000 (420)
2"	8.00	4.750	4.23	5.82	2900 (200)	5800 (400)
2 1/2"	11.00	7.500	9.08	12.01	2600 (180)	4500 (310)
3"	12.50	9.000	13.30	18.02	2300 (160)	3900 (270)

* BODY ONLY CONSISTS OF BENT FLARED PIPE SECTION AND CONES. FOR TOTAL ASSEMBLY WEIGHT, ADD APPROPRIATE FLANGE WEIGHTS TO BODY WEIGHT.

- TO ORDER COMPLETE ASSEMBLY REFERENCE PAGE B25
- OTHER RADII AVAILABLE (CONSULT FACTORY)

MATERIAL: CARBON STEEL, (STAINLESS STEEL AVAILABLE)

• REDUCING FLANGES AND CONES ARE AVAILABLE (REFERENCE PAGES B16-B19)

FOR FLARE FLANGE ASSEMBLIES UTILIZING REDUCING FLANGES AND CONES ADD (R) TO FLANGE AND CONE CODE NUMBERS.

ie. SAE code 61 flare flange with clearance holes - code number FC34 would be FCR34-(flange size)

REDUCING PART NO. (EXAMPLE): A/FFE - SCH40-050 - FCR34-075 - FC34 - COR - CO

Consult factory for ordering assistance



Flare Flange Elbow Assembly

Complete Assembly Part Number

Code		A	/	FFE	-	Body & Cone Material	-	Size & Schedule	-	Flange 1	-	Flange 2	-	Cone 1	-	Cone 2	-	Options	
Assembly		A																	
Flare Flange Elbow		FFE																	
Body & Cone Material Carbon Steel (Standard) Ref. page (B24)	No Designation Required																		
Body & Cone Material Stainless Steel (Optional) Ref. page (B7)	TMP304SS	304																	
	TMP316SS	316																	
	†TMP2205SS	2205																	
Body Size & Schedule	1/2"	SCH40-050 SCH80-050																	
	3/4"	SCH40-075 SCH80-075																	
	1"	SCH40-100 SCH80-100																	
	1 1/4"	SCH40-125 SCH80-125																	
	1 1/2"	SCH40-150 SCH80-150																	
	2"	SCH40-200 SCH80-200																	
	2 1/2"	SCH40-250 SCH80-250																	
	3"	SCH40-300 SCH80-300																	
	Flange Type Carbon Steel Yellow Zinc Dicromate Plated Ref. pages (B8-B11)	FFC34 SAE Code 61 W/Clearance Holes	FC34																
		*FFT34 SAE Code 61 W/Tapped Holes	FT34																
FFC64 SAE Code 62 W/Clearance Holes		FC64																	
*FFT64 SAE Code 62 W/Tapped Holes		FT64																	
FFC74 ISO 6164 W/Clearance Holes		FC74																	
**FFC49 TMI® 9-Bolt W/Clearance Holes		FC49																	
Cone Type Ref. pages (B12-B15)	Cone - Flat Face	CF																	
	Cone - 'O' Ring Face	CO																	
Options	Viton	V																	
	Painted (Specify)	P																	
Complete Stainless Steel Assembly: (including flanges)	SS																		

† TMP2205SS PIPE IS ONLY AVAILABLE IN 1 1/4"-2" SCHEDULE 80 SIZES

**FOR USE ONLY WITH 9-BOLT BALL VALVE CONNECTION (REF. PG P10)

* NORMALLY USED FOR CONNECTION TO SPLIT FLANGE TYPE ENDS

PART NO. (EXAMPLE): A/FFE - SCH40-050 - FC34 - FC34 - CF - CO

- ASSEMBLY WORKING PRESSURE RATINGS ARE SUBJECT TO THE LESSER OF THE FLANGE OR BODY RATINGS
- SEE REFERENCE PAGES INDICATED ABOVE FOR PRESSURE RATINGS
- FOR BOLT KITS - REFERENCE SECTION R



